



is designed for large scale jobs on asphalt, loose and semi-cohesive materials or stabilizations. It is a tandem vibratory roller with an articulated frame and two smooth machined drums. Both drums are driven and vibrating. The drive of all machine functions is hydrostatical. The machine is equipped with Cummins engine, hydraulic Sauer-Danfoss. It fulfils requirements of pollutants emission directives 97/68/ECE Stage 2 and EPA/CARB Tier 2. The machine meets the CE marking conditions.

STANDARD

VH 1700

- Cabin ventilated and heated
- Rotating and sliding seat with steering wheel
- Both drums vibrating
- Two mode vibrators
- Two frequencies
- Articulated frame
- Pre selection of the travel and vibration
- Both drums are hydrostatically driven
- Working halogen headlights
- Painting STA: yellow, grey

OPTIONS

VH 1700

- Operator platform without cabin with rails
- Lockable vandal guard
- Engine CUMMINS 6BTA5.9-C165 (123 kW) - Stage 1/Tier 1
- ROPS protection (obligatory for CE)
- ROPS canopy (mounted to ROPS)
- Air conditioning
- Stepless frequency
- Beacon and turn indicators
- Special painting

MAXIMAL COMPACTED LIFT THICKNESS AT OPTIMAL WORKING CONDITIONS (m)

	Asphalt	Sand/Gravel	Mixed soils	Silt	Clay	Stabilization
VH 1700	0,20 m	0,60 m	0,50 m	-	-	0,40 m



size (mm)	A	D	G	H	H1	H2	L	T	W	W1	W2
VH 1700	3770	1570	425	3400	2810	270	6850	25	2200	2400	100

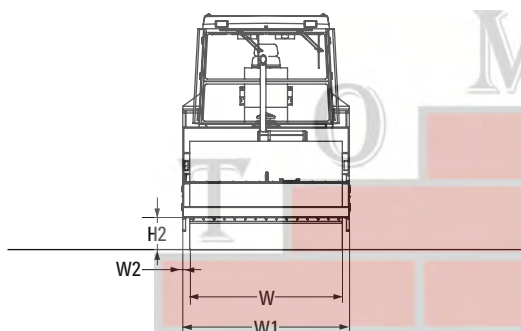
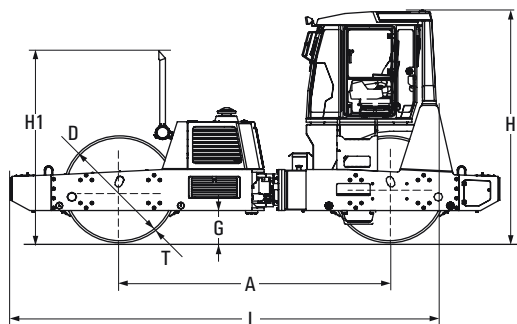

CAPACITY	VH 1700
Operating weight (CECE)	17030 kg
Compacting width maximum	2200 mm
Drum offset	0 mm

WEIGHTS	
Operating weight maximum	17740 kg
Front drum load (CECE)	7814 kg
Rear drum load (CECE)	9216 kg
Front drum linear load	35,5 kg/cm
Rear drum linear load	41,9 kg/cm

STEERING	
Steering angle (+ -)	35 deg
Oscillation angle (+ -)	10 deg
Turning radius inner (edge)	5000 mm
Transversal stability - straight	30 deg

RIDING CHARACTERISTIC	
No. of travel speeds	2
Maximal speed	12 km/h
Gradeability without vibration	32%
Gradeability with vibration	32%

BRAKES	
Operation	Hydrostatic
Parking	Multi disc
Emergency	Multi disc

VIBRATION	
Amplitudes	0,7 / 0,35 mm
Frequencies	45 / 60 Hz
Centrifugal forces	180 / 160 kN

WATERING	
Watering	Pressure
No. of pumps	2
Water filtration stages	2

TANKS	
Fuel	430 lt
Watering water	1080 lt

ELEKTROINSTALLATION	
Voltage	24 V
Capacity of batteries	2x100 Ah

ENGINE	
Make	Cummins
Type	QSB5.9-30-T-C115
Rated power	116 kW
Standard	ISO 3046/1 (DIN 6271)

Technical modifications and data reserved.
Machines may be shown with options.

